

# LAB-02

## LAB-MACHINE FOR INTERNAL COATING TECHNOLOGY



**SPECIAL PRICE**  
FOR THE PRODUCT LAUNCH

**195.000 EUR**

The price includes the following services:

- Equipped with 2 × **Sprimag S8** spray guns
- Laboratory lacquer supply
- One week of on-site commissioning and operator training\*

\*Applies only within Europe

## LAB-02 Laboratory machine for the simulation of wet paint coating processes

The LAB-02 is a flexible laboratory machine designed for realistic simulation of current HIL process parameters and basic settings for spray guns. It enables a three-stage coating process using different nozzle heads and supports the development and optimization of internal coatings for aluminum tubes, aerosol cans, and aluminum beverage bottles under laboratory conditions.

The horizontal workpiece orientation enables precise, production-oriented coating application. The system supports both the 3-stage process (2x body, 1x shoulder/bottom) and the 2-stage process (1x body, 1x shoulder/bottom), and offers additional flexibility thanks to the second spray gun in the system. Coating speeds ranging from 0.2 m/s to 1.2 m/s enable practical test series under realistic production conditions.



### BENEFITS

- Test and development platform for process parameters
- Experimental testing of various types of coatings, process speeds, and pressure settings
- Basic settings for spray guns
- Chuck adaptable to many different tube and can formats
- Integrated control cabinet
- Forklift-compatible and therefore easy to transport

### FEATURES

- Linear servo drive system of the two integrated spray guns with separate height and lateral adjustment
- Pneumatic offset movement of the chuck between painting procedures
- Quick-change system of the spray guns
- User-friendly operation thanks to a modern HMI panel
- High-quality stainless steel design

#### Optional functions:

- Intermediate drying or flash-off through targeted airflow, ideal with low-speed rotation
- Preheating of spray gun extensions to ensure consistent and reproducible coating conditions

### APPLICATION TECHNOLOGY

The laboratory machine is equipped with two spray guns as standard. All common Sprimag spray guns can be integrated, such as the S-8, S-233, and S-7MD. Nozzle extensions ranging from 200 mm to 400 mm can be used.



The intuitive HMI with multi-touch technology offers exceptional flexibility in operation. Thanks to its tiltable design, the 12-inch display can be individually adjusted into various working positions.

The integrated door lighting system ensures clear and optimal visibility of the open working area, as well as of the coating process taking place inside the enclosed interior area.

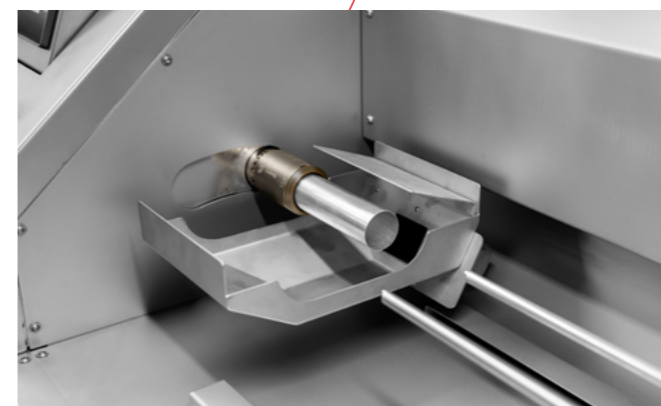

The extraction tray beneath the holding chuck can be slid out and is easy to remove without tools. This allows a convenient and easy cleaning and quick replacement of the holding chuck.

The system is equipped with a multi-coupling interface that serves as a quick-change system, allowing rapid and easy replacement of the spray units, including the hoses.

## TECHNICAL DATA

Parameter	Specification
Product range	Aluminum tubes / Aerosol cans / Beverage bottles
Product diameter range	$D_{\min} = 10 \text{ mm}$ , $D_{\max} = 80 \text{ mm}$
Product length range	$L_{\min} = 70 \text{ mm}$ , $L_{\max} = 270 \text{ mm}$
Coating speeds	0.2 m/s up to 1.2 m/s
Application Technology	2x Type S-233, 2x Type S-8, or 2x Type S-7MD Extensions from 200 mm to 400 mm
Electrical connection power	12 kVA

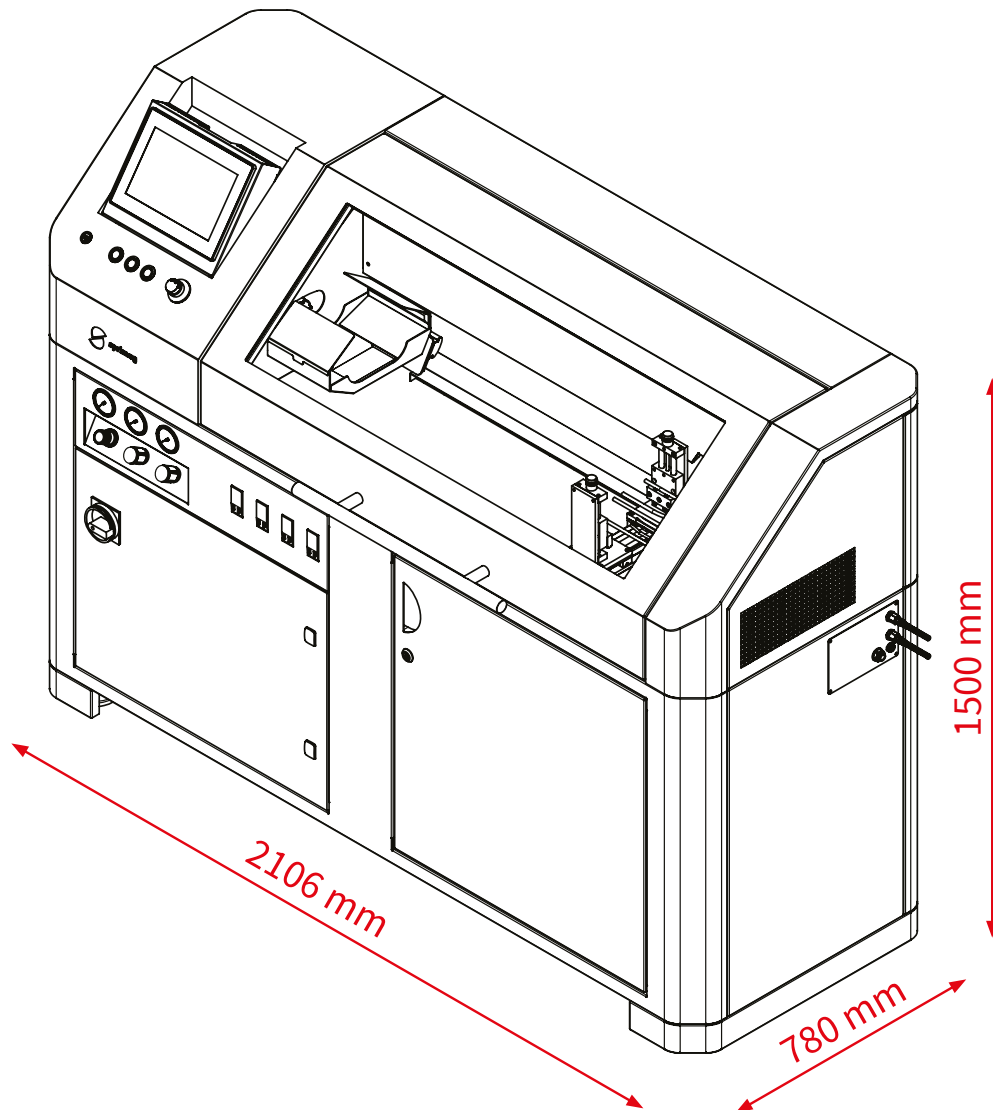

**Sprimag Spritzmaschinenbau GmbH & Co. KG**  
 Henriettenstrasse 90  
 D-73230 Kirchheim unter Teck · Germany  
 Tel. +49 (0) 7021 / 579 0 · Fax +49 (0) 7021 / 417 60  
 www.sprimag.com · info@sprimag.de

