

# EAM-4

## ELECTRIC ANNEALING MACHINE



## EAM-4 The new standard for soft annealing of aluminum tubes according to DIN EN 16285

With the EAM-4, Sprimag sets new standards in efficiency, sustainability, and process reliability. The innovative electric annealing machine for aluminum tubes enables production speeds of up to 200 tubes per minute while drastically reducing energy consumption compared to conventional tube annealing ovens.

The patent-pending technology includes high-precision temperature control for targeted soft annealing and burning off lubricant residues. The EAM-4 is impressive both technically and economically.

### Your benefit:

Homogeneously annealed tubes, lower operating costs, and a significantly more sustainable production process.

## BENEFITS

- Highest energy efficiency with maximum production output
- Sustainable solution for modern aluminum tube production
- Precise, reproducible annealing results
- High ease of use thanks to modern HMI design
- No contamination from chain lubrication
- Reduced system complexity for shorter evacuation times

## FEATURES

- Production speeds of up to 200 tubes/min
- Electrically heated with annealing temperatures up to 510 °C
- Precise temperature control (+/- 3 °C) throughout the entire process
- Low number of tubes in the annealing area
- Innovative heating system with contact heating
- Safe tube transport without transport chain
- Individual monitoring at the take-off for safe transfers

### Heat-up curve:

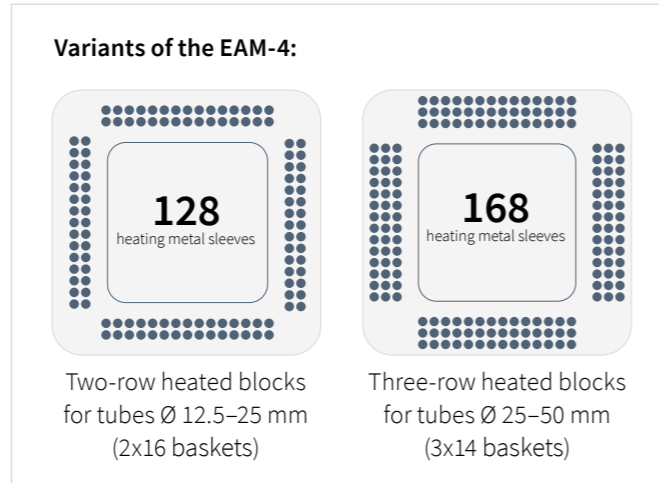
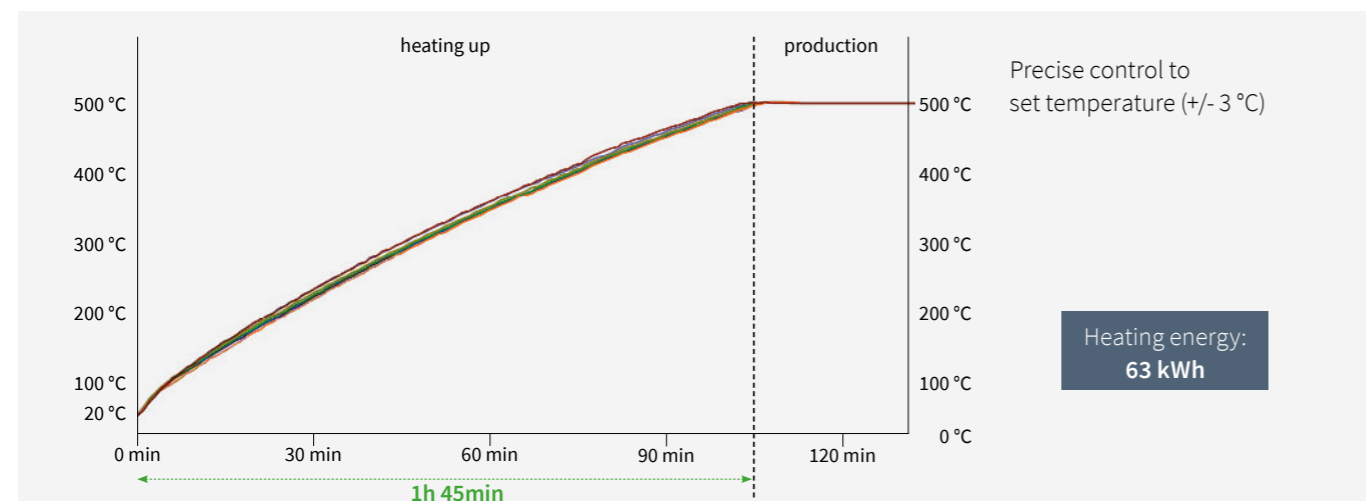

## SUSTAINABILITY

The heart of the EAM-4 is its electric heating process with direct contact heating and efficient insulation. This allows a transition away from fossil fuels while maintaining extremely low energy consumption.

### Comparison of energy consumption (production):

	TGO – gas-heated	EAM – electric
two-row variant	1.347 kWh / 24 h	194 kWh / 24 h
three-row variant	2.352 kWh / 24 h	360 kWh / 24 h

**Energy savings > 75 %**  
compared to conventional  
tube annealing ovens.

The intuitive HMI design with multi-touch technology provides new possibilities for visualization.

Two basket segments, each with 16 baskets (two-row variant) or 14 baskets (three-row variant), for continuous and safe take-off of the tubes after the annealing process.

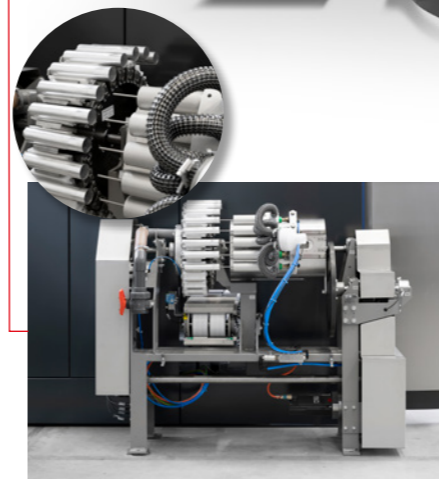
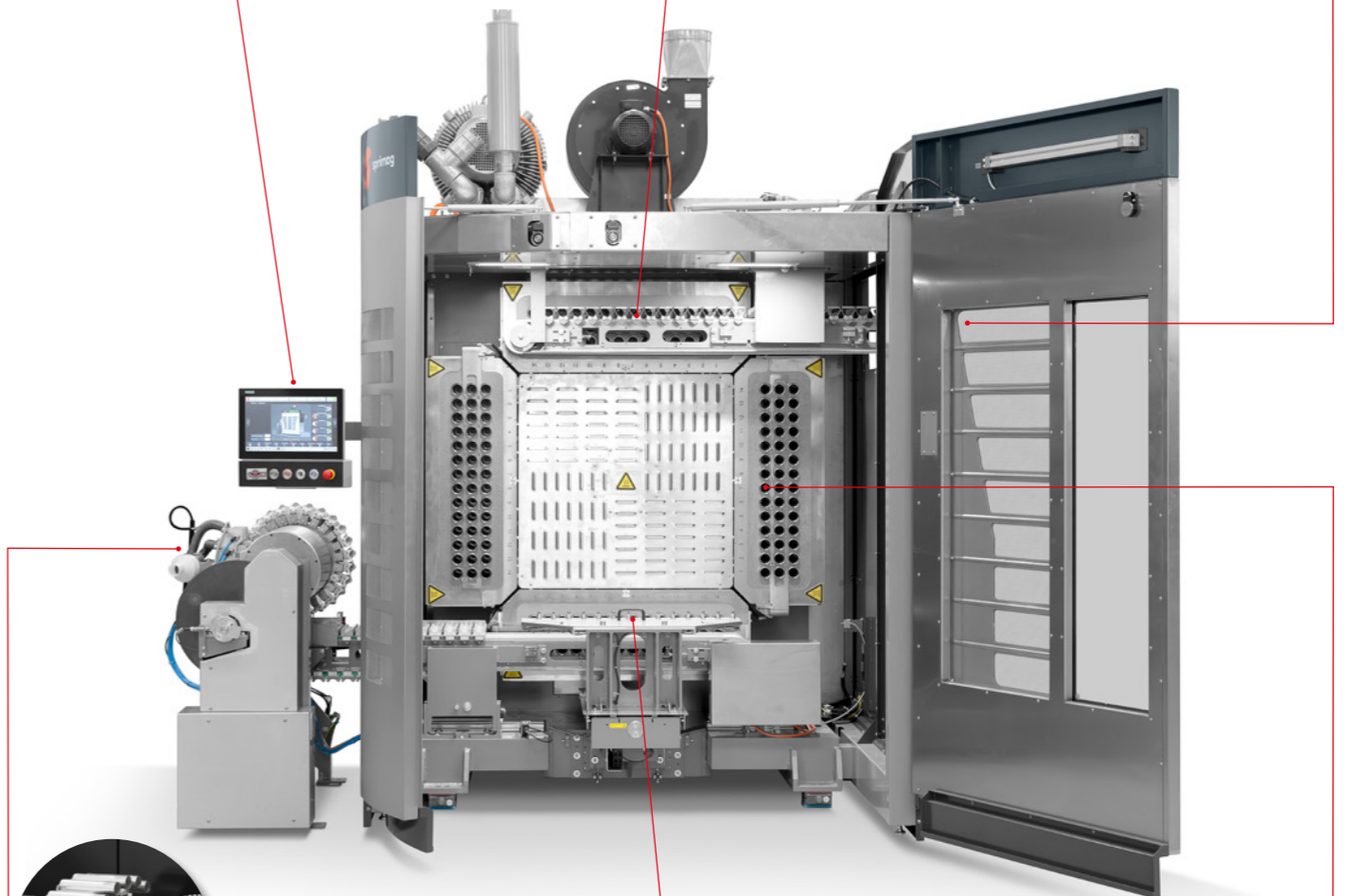

Optionally, a chip blow-off drum (CBD) with targeted extraction and an extended blow-off process can be added.



Safe tube transport and individual monitoring at the take-off for reliable transfer of the tubes into and out of the metal sleeves.



Four heated blocks with a total of 128 (two-row) or 168 (three-row) integrated heated metal sleeves with high-efficiency insulation material.

## TECHNICAL DATA

Parameter	Specification
Product range	Aluminum tubes
Product diameter range	$D_{\min} = 10 \text{ mm}$ , $D_{\max} = 50 \text{ mm}$
Product length range	$L_{\min} = 70 \text{ mm}$ , $L_{\max} = 220 \text{ mm}$
Production capacity	up to 200 tubes per minute
Annealing temperature	up to max. 510 °C
Electrical connection power	70 kVA

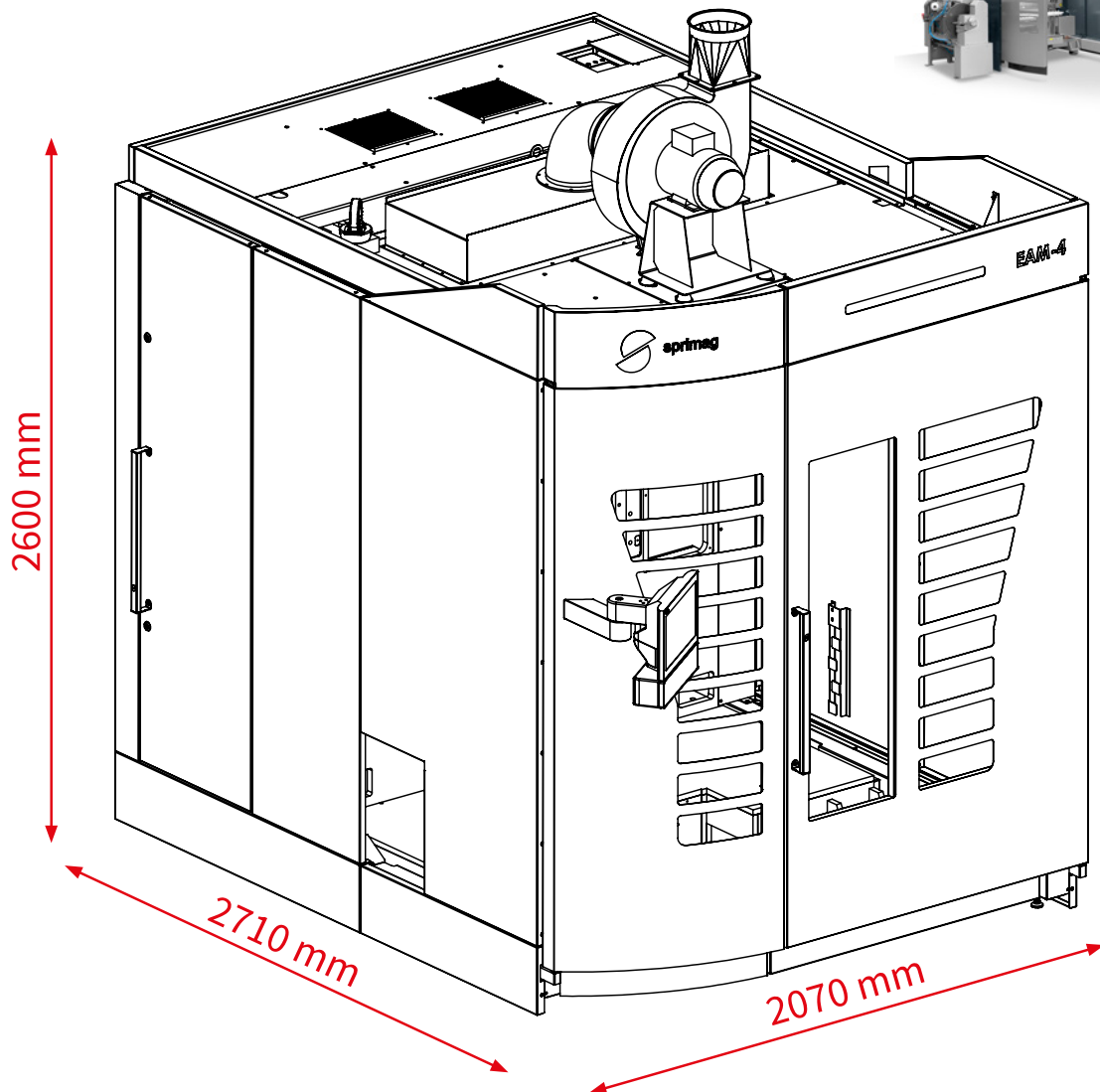

**Sprimag Spritzmaschinenbau GmbH & Co. KG**  
 Henriettenstrasse 90  
 D-73230 Kirchheim unter Teck · Germany  
 Tel. +49 (0) 7021 / 579 0 · Fax +49 (0) 7021 / 417 60  
 www.sprimag.com · info@sprimag.de

